BASTA BOATLIFTS

OVER-CENTER HYDRAULIC ALUMINUM LIFT

5,500 lb Capacity Boat Lift
Models 5.5k60



866-GoBasta | GoBasta.com

DANGER

- Do not exceed the maximum weight capacity specified for the lift. Maximum weight capacity can be found on the cover of this manual and on the H frame of the lift. Improper use or failure to follow this instruction can cause property damage, serious injury, or death.
- Never use for lifting humans or animals. Improper use or failure to follow this instruction can cause property damage, serious injury, or death. The lift should only be used for lifting boats & watercraft.
- Always avoid being under, and maintain adequate clearance from, the lift. Failure to follow this instruction can cause serious injury or death.
- Always use AGM batteries and follow battery manufacturer's warnings and instructions. Improper use, or use of other batteries, have the potential to produce flammable hydrogen gas which can result in serious injury or death.

WARNING

- Visually inspect all parts and assemblies for damage or defects prior to assembling lift.
- Install the lift on firm and level ground.
- Verify the lower frame of the lift is level before each use.
- Do not play on or near the lift.
- Do not service the unit with the watercraft on the lift.
- High pressure hydraulics can penetrate skin. Oil injected into the skin from high pressure systems can cause severe injury. In the case of injury, seek medical attention immediately.

CAUTION

- Do not install the lift alone.
- The lift should only be used for lifting boats & watercraft.
- Passengers should stand clear of the lift when the lift is in operation.

Basta Boatlifts are protected by one or more US Patents

www.gobasta.com/patents

TABLE OF CONTENTS



SAFETY	P 2
PARTS LIST AND DIAGRAMS	P 4-5
ASSEMBLY INSTRUCTIONS	P 6-16
OPERATIONAL INSTRUCTIONS	P 17
REMOTE CONTROL FOB INFORMATION	P 18
TROUBLESHOOTING / FAQ	P 19
MAINTENANCE	P 20-21
WARRANTY	P 22

PRODUCT INFORMATION

Model #: _____

Serial #: _____

Purchased From: _____

Date of Purchase: _____

Contact Name: _____

Phone #: _____

Notes: _____

IMPORTANT!

**WARRANTY MUST BE
REGISTERED WITHIN 30 DAYS
OF INSTALLATION.**

TO REGISTER, SCAN HERE OR VISIT
WWW.BASTABOATLIFTS.COM/SUPPORT



PARTS LIST - BOAT LIFT



ITEM	PART NO.	DESCRIPTION	QTY.
AA	VAR.	Leg	4
BB	W117-0001	Foot Pad	4
CC	W105-0045	Side Rail, Left	1
DD	W05-0044	Side Rail, Right	1
EE	A431-0096	H-frame, Forward	1
FF	AA431-0095	H-Frame, Aft	1
GG	SEE PG. 10	Hydraulic Cylinder	1
HH	A427-0077	Bunk Rail Assembly, Left	1
JJ	A427-0076	Bunk Rail Assembly, Right	1
KK	M621-1002	Base Pivot Bushing	8

ITEM	PART NO.	DESCRIPTION	QTY.
N/A	W114-0013	Bunk Rail Weldment, Left (part of HH)	(1)
N/A	W114-0014	Bunk Rail Weldment, Right (part of JJ)	(1)
N/A	W410-0069	Bunk Board Assembly (part of HH, JJ)	(2)
N/A	S313-0007	Washer, flat 5/16 SS (part of HH, JJ)	(6)
N/A	S322-0007	Washer, lock 5/16 SS (part of HH, JJ)	(6)
N/A	S342-0007	Nut, 5/16-18 SS (part of HH, JJ)	(6)

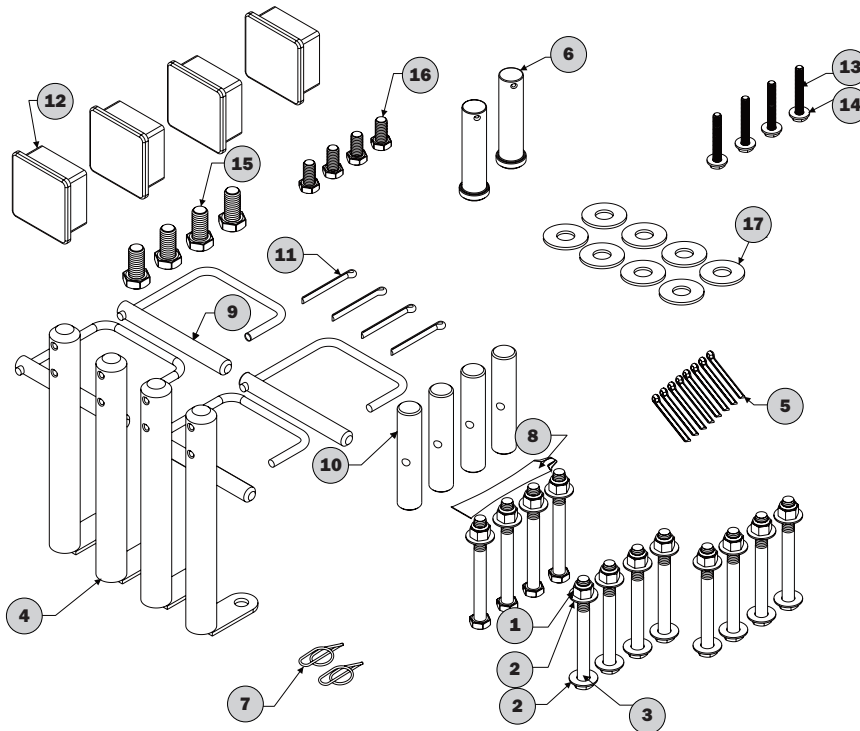

ITEM	PART NO.	DESCRIPTION	QTY.
1	S362-0008	Nut, 3/8-16 Nylock SS	12
2	S313-0008	Washer, Flat 3/8 SS	24
3	S103-0516	Bolt, Hex Head 3/8-16 x 3.75 SS	12
4	S503-0012	Base Pivot Pin SS	4
5	S520-1604	Cotter Pin, 5/32	8
6	S103-0516	Clevis Pin, 3/4 x 3.5 SS	2
7	S522-0801	Ring Cotter Pin .091 x 3/4 SS	2
8	Y356-0003	Anti-Seize Grease Packet	1
9	S532-1801	P Pin, SS	4

ITEM	PART NO.	DESCRIPTION	QTY.
10	S503-0019	Bunk Pin, SS	4
11	S520-1706	Cotter Pin 3/16 x 2.0 SS	4
12	F730-0021	Plastic Cap for 2-1/2" OD SQ Tube	4
13	S103-0338	Bolt, Hex Head 1/4-20 x 1.75	4
14	S322-0006	Washer, Lock 1/4 SS	4
15	S103-0705	Bolt, Hex Head 1/2-13 x 1.0 SS	4
16	S103-0503	Bolt, Hex Head 3/8-16 x 3/4 SS	4
17	S313-0013	Washer, Flat 3/4 SS	8

ITEM	PART NO.	DESCRIPTION	QTY.
A1	R812-0023	Remote Control Master Unit	1
B1	R283-0002	Solar Controller	1
C1	R310-0001	On/Off Switch	1
D1	R310-0002	Up/Down Switch	2
E1	R281-0004	Solar Panel Assembly	1
F1	C243-0003	Enclosure	1

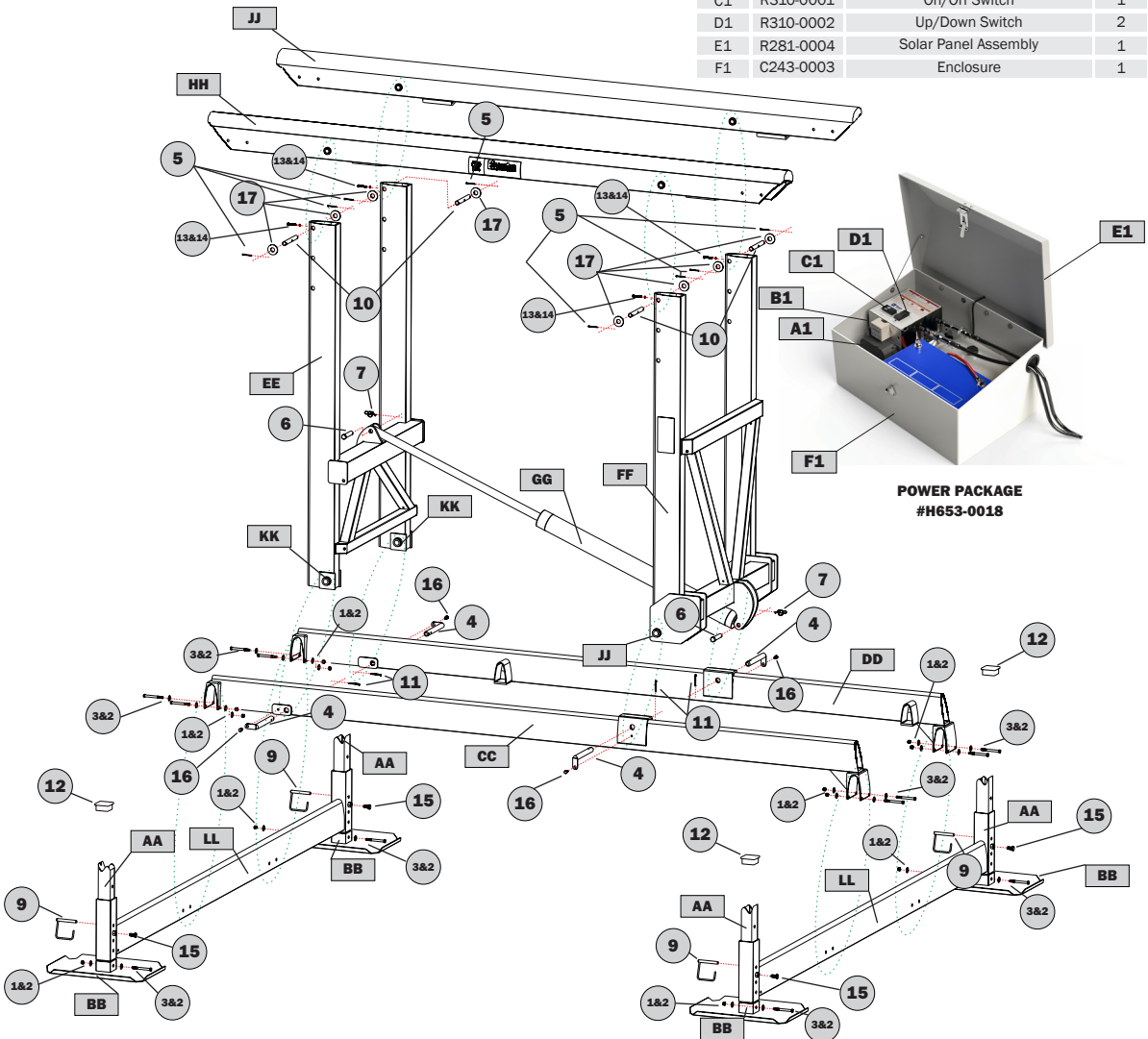

Symbol Glossary for the following pages:

1 indicates an illustration for a procedure.

AA indicates a major part described in the parts list on pages 4 and 5.

a or **c+d** indicate hardware items shown above and described in the parts list on pages 4 and 5.

Tools needed for the job:

- Tape measure
- Level
- 9/16 ratchet
- 9/16 box-end wrench
- Large slip joint pliers
- Medium sized adjustable wrench

ASSEMBLY INSTRUCTIONS



Pictured: Steps 1-3

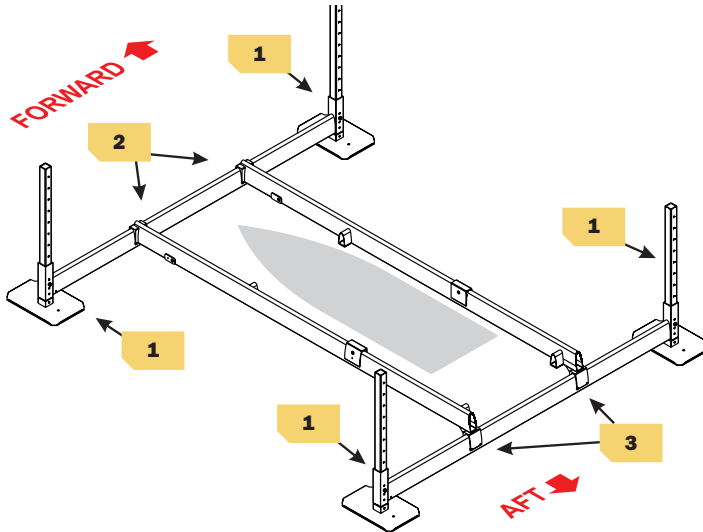

Use a small amount of 'moly' lube on bolt threads through the assembly process.

Do not tighten any hardware until step 12.

Do not tighten bolt '15' until step 16.

- QTY 4: 3/8 x 3.75" bolts ("6")
- QTY 4: 3/8 nylon insert lock nuts ("1")
- QTY 8: 3/8 flat washers ("2")
- QTY 4: leg P pins ("9")
- QTY 4: 1/2 x 1.0" bolts ("15")

NOTE: The 3 different holes shown can be used for pin '9' to allow fine height adjustment during installation.

1 Feet & Legs (4 Places)

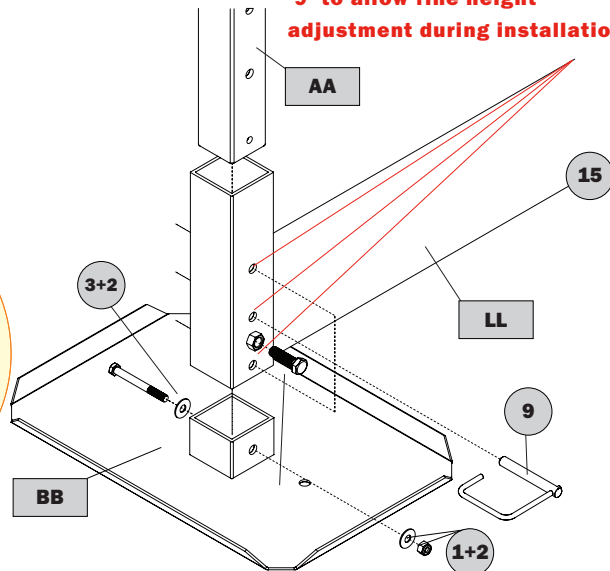

2

Forward Crossmember

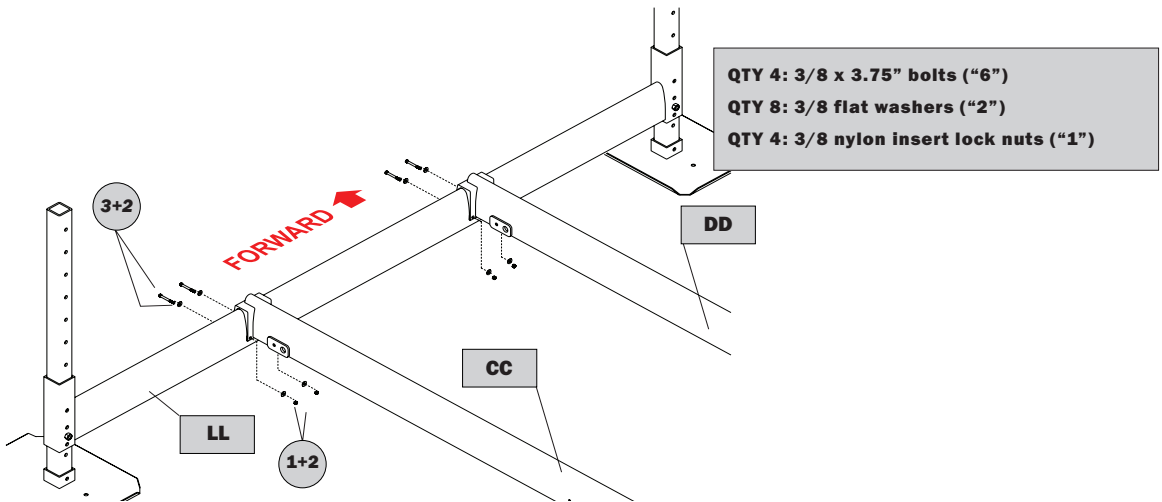

Assemble lift on level ground and adjust legs so that lift base frame is level during lift assembly.

3

Aft Crossmember

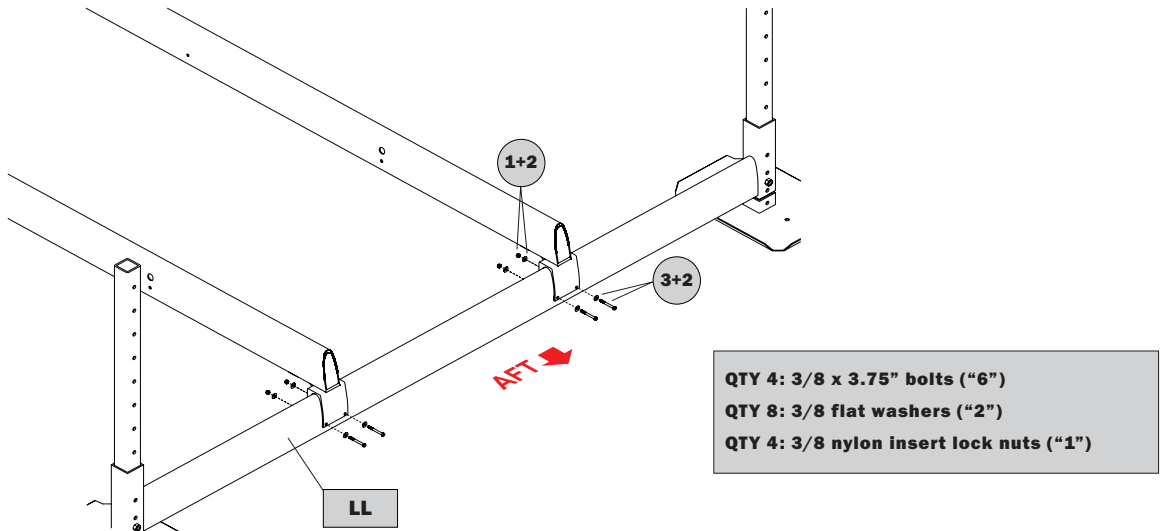

Pictured: Steps 4-5

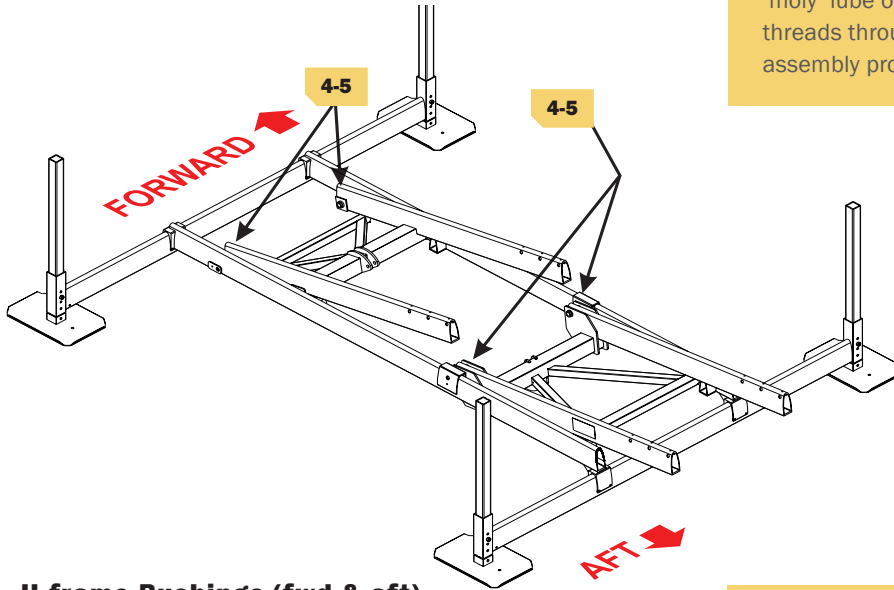

Use a small amount of 'moly' lube on bolt threads through the assembly process.

4 H-frame Bushings (fwd & aft)

Bushings are pre-installed - remove cable ties used for shipping.

Forward H-frame is shown. Aft H-frame installation is the same.

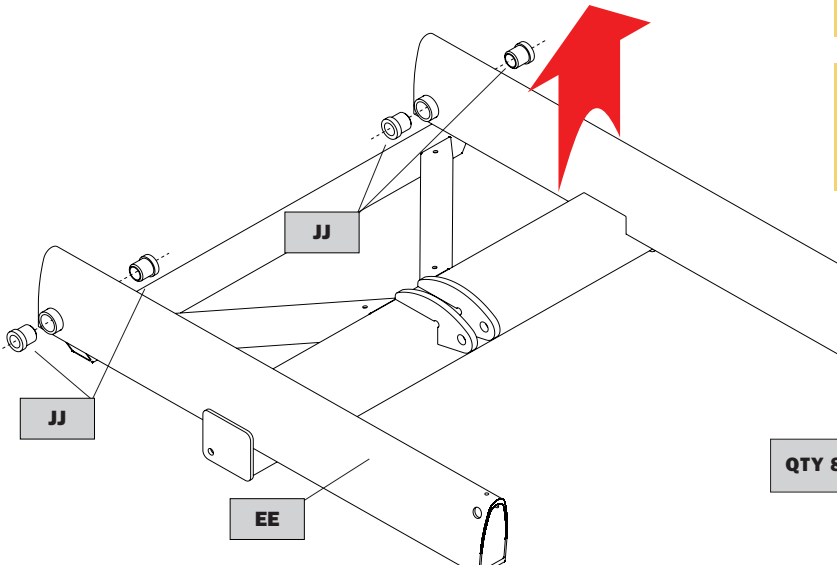

QTY 8: plastic bushings ("JJ")

5

H-frame Bushings (fwd & aft)

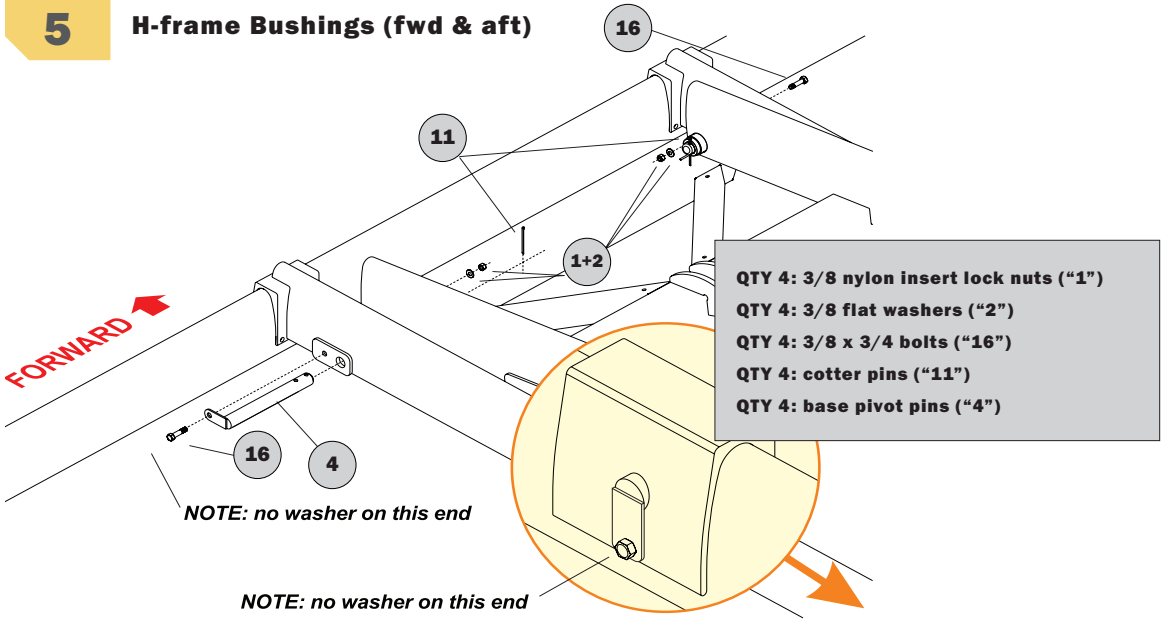

ASSEMBLY INSTRUCTIONS



Pictured: Steps 6

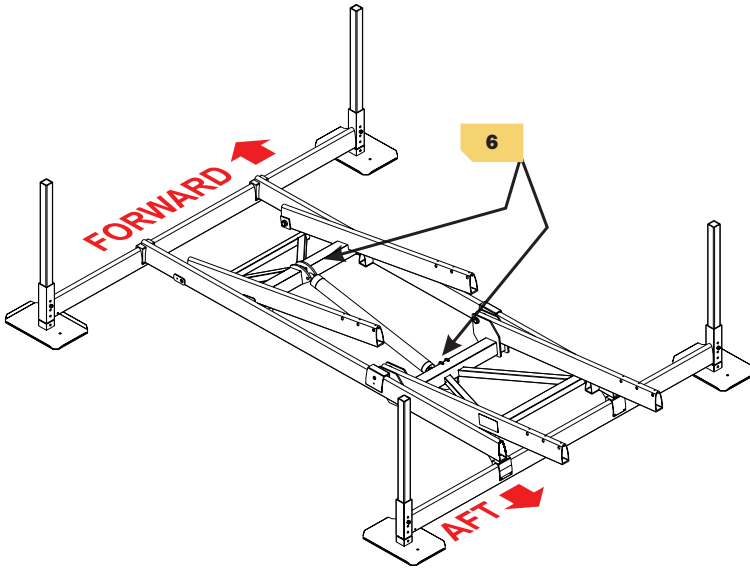

Use a small amount of 'moly' lube on bolt threads through the assembly process.

Install cylinders with lift in 'down' position.

6 Cylinder

- QTY 2: 3/4 x 3.5" clevis pin ("6")
- QTY 2: 3/4 ring type cotter pin ("7")

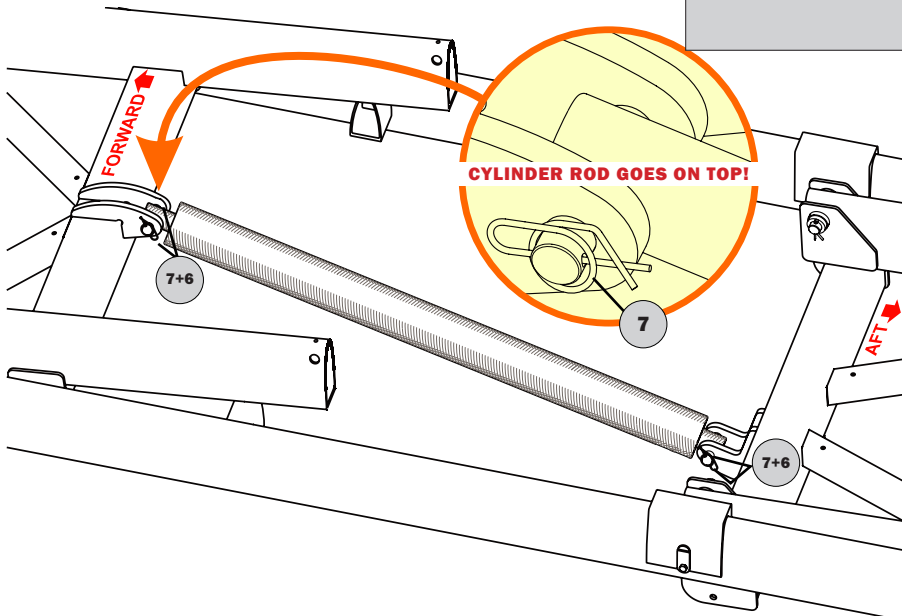

ASSEMBLY INSTRUCTIONS



Pictured: Step 7

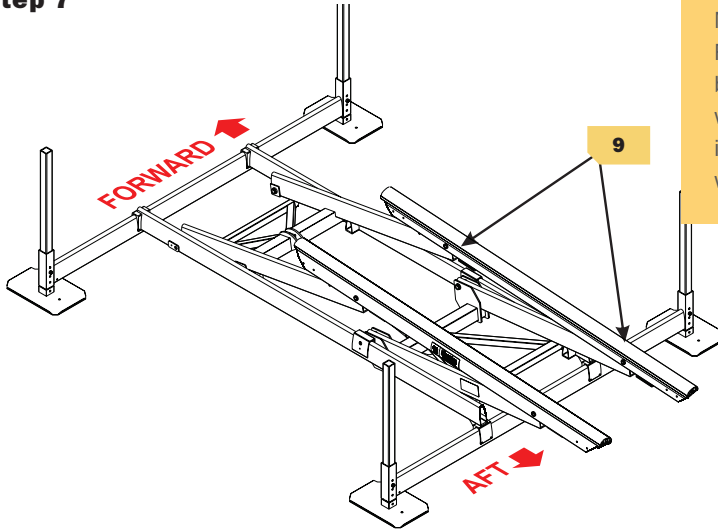

Model 4.5k37 only:
Remove black bunk
bushings and replace
with shorter white bush-
ings before proceed-
ing with this step.

7 Bunk Rail Assembly

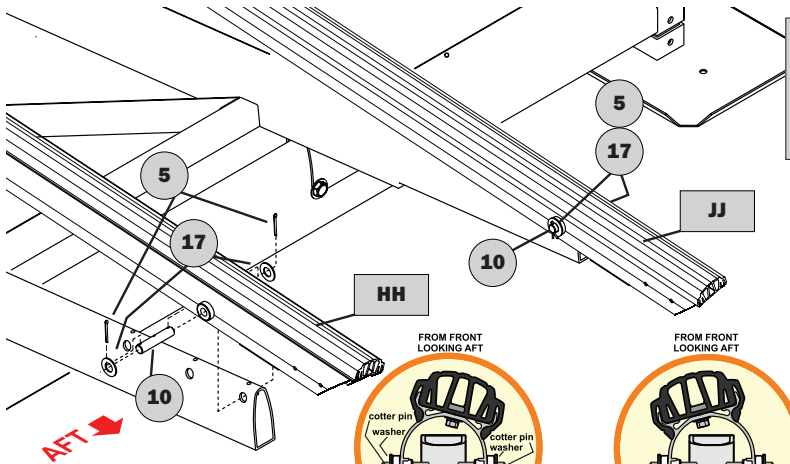

- QTY 4: bunk pivot pins ("10")
- QTY 8: 3/4 ring type cotter pin ("5")
- QTY 8: 3/4 flat washers ("17")

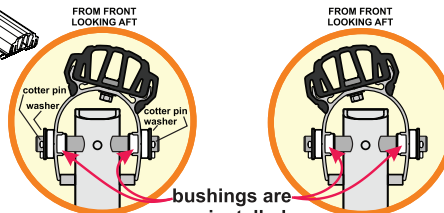

* Right Rail [NN] * Left Rail [MM]

The angles and directions of bunk rail assemblies **MUST** face the directions show.

8 Complete Power Unit Package

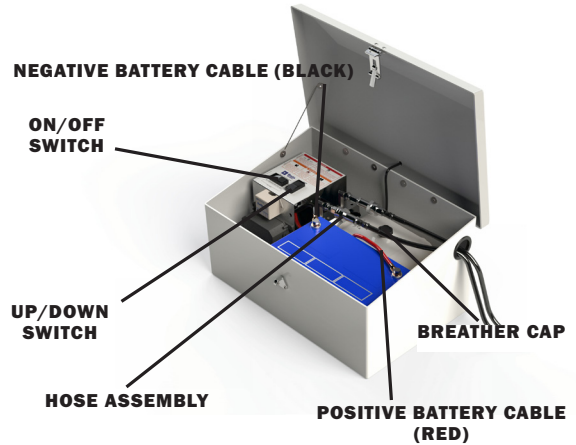
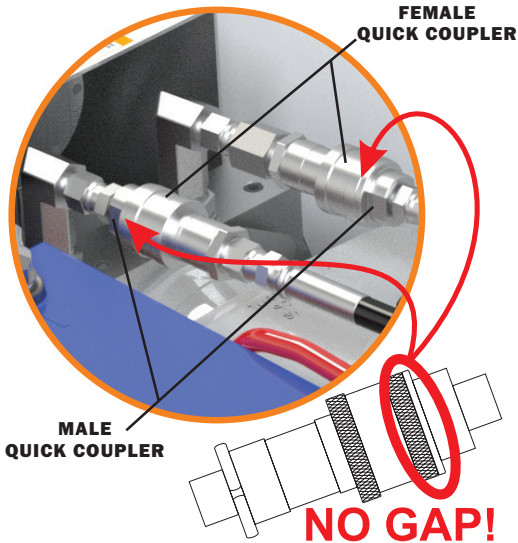

Step 1: Slide the Hydraulic Hose Assembly through the access hole in the side of the fiberglass enclosure and attach the ends to their corresponding Quick Couplers. Ensure each Quick Coupler is fully seated, tight and with no gap at the connection joint.

Step 2: Remove shipping plug in hydraulic reservoir and replace with breather plug before first use.

Step 3: Install Battery as shown. Connect the Red Battery Cable to the positive terminal (+) and the Black Battery Cable to the negative terminal (-).

Step 4: Before moving into the water, test the lift on dry ground using the Up/Down Switch and the Key Fob Transmitters. Inspect the system for leaks.

IMPORTANT

ONLY ADD FLUID WITH LIFT IN DOWN POSITION

Hydraulic fluid shown with lift in the DOWN position

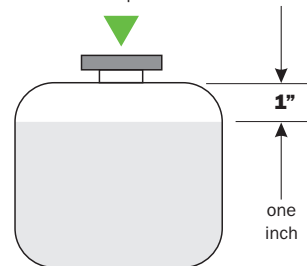

Pictured: Step 9

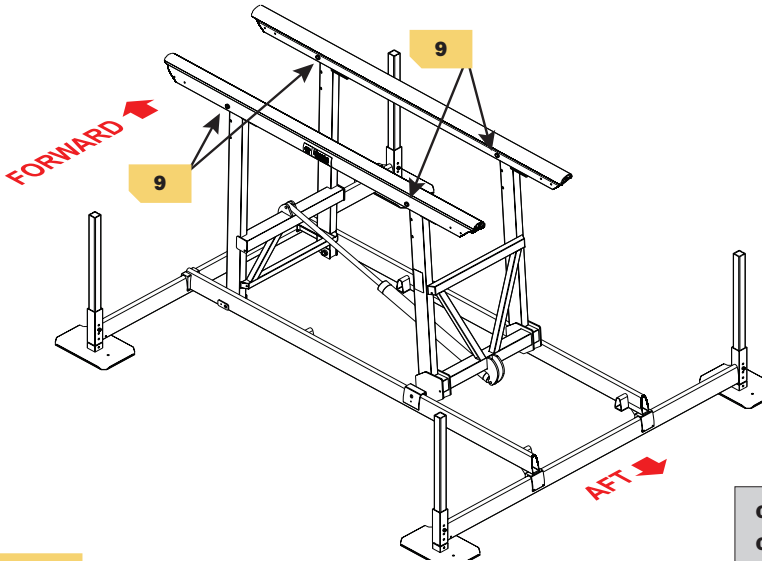

Use a small amount of 'moly' lube on bolt threads through the assembly process.

Raise lift to install 1/4 x 1.75" bolts ("13").

QTY 4: 1/4 x 1.75" bolts ("13")
QTY 4: 1/4 lock washers ("14")

9 Bunk Rail Assembly

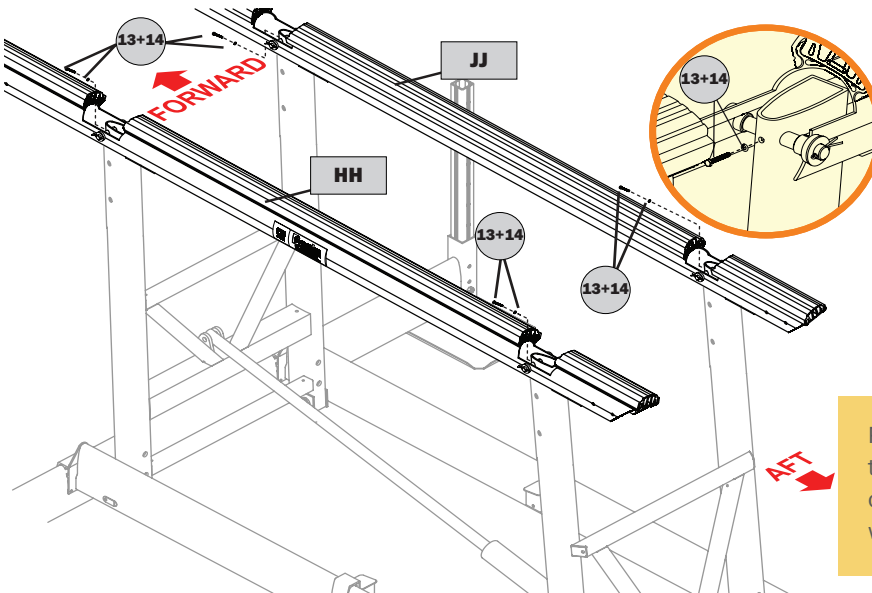

Placement may need to be modified based on watercraft draft and weather conditions.

PLACEMENT INSTRUCTIONS



10

Test lift on dry ground for leaks, remote control function and correct operation before moving into water. Tighten all hardware.

11

Lower the lift completely, then raise it slightly. Disconnect the Hydraulic Hose Quick Couplers in the Power Unit box to separate it from the lift.

12

Move the lift to final destination. Use this diagram to help place the lift. Lift placement should be so that the top of the aft end of the bunks are one foot above the high-water mark when the lift is in the full up position, and one foot below the low water mark, when the lift is in the down position.

USE THIS DIAGRAM TO HELP PLACE THE 4.5k37 LIFT

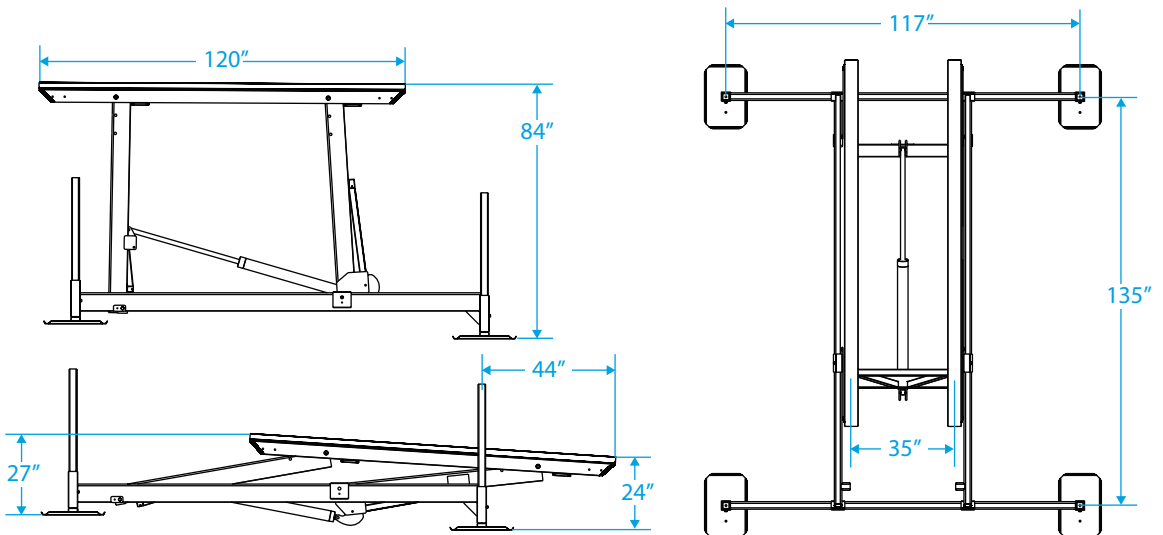

IMPORTANT: The leveling process must be completed to ensure stability of the lift frame and Over-Center safety lock.

13

Level the lift following these instructions while referencing image below:

Step 1: Use a tape measure (reference image on right) to determine that the lower frame is level.

Step 2: If the lower frame needs to be raised start with the lowest corner first then work your way around the lift in a circle, corner to corner. Adjust the lift legs as needed.

Step 3: To make adjustments, first make sure the lift is properly supported.

Then, loosen the anti-sway bolts, remove the P-pin and raise or lower the lift crossmember on the leg. Level the lift one corner at a time, while making sure not to have more than 5" of difference in height between the corners to prevent binding.

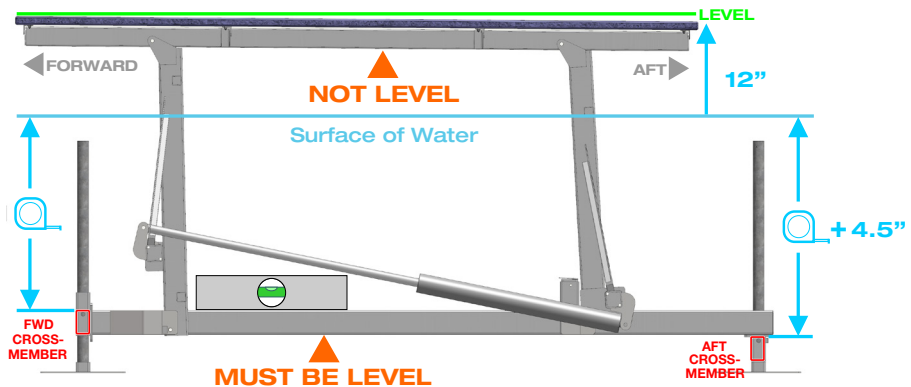

Leveling requires a second person to support the crossmember while making adjustments.

If the lift is too heavy for two people, a ratchet strap or winch system will be required to raise/lower the frame corners.

Contact Basta at 866-GO-BASTA for additional help.

14

Re-connect the Hydraulic Hose Quick Couplers inside the Power Unit box.

Fully raise lift and finish adjusting the legs so that the base frame is level side-to-side and forward-to-aft. After the lift is assembled and installed, all fasteners should be checked for proper tightness and reinspected periodically.

15

Load the boat onto the lift using the following operational instructions:

1. Align the boat so it is centered between the bunks side-to-side.
2. Move the boat forward to position its center of gravity near the bunks' centers.

16

Perform the following adjustments to finalize the lift installation:

1. Disembark and raise the boat.
If more than two inches of settling occurs, STOP, carefully lower the lift to remove the boat and re-level the lift. Continue repeating this step until the lift can be raised into the full Over-Center™ position without settling.
2. Remove the boat. Verify that the lift frame is level. Re-level the framework if necessary.
3. Check all bolts for proper tightness.

OPTIONAL

The lift legs can be cut off above the leg sockets after installation for a cleaner look. First, make sure that the lift has fully settled and has been re-leveled.

NOTE: If you plan to add a canopy, relocate the lift into deeper water, or load a heavier vessel in the future, you must keep the existing leg length.

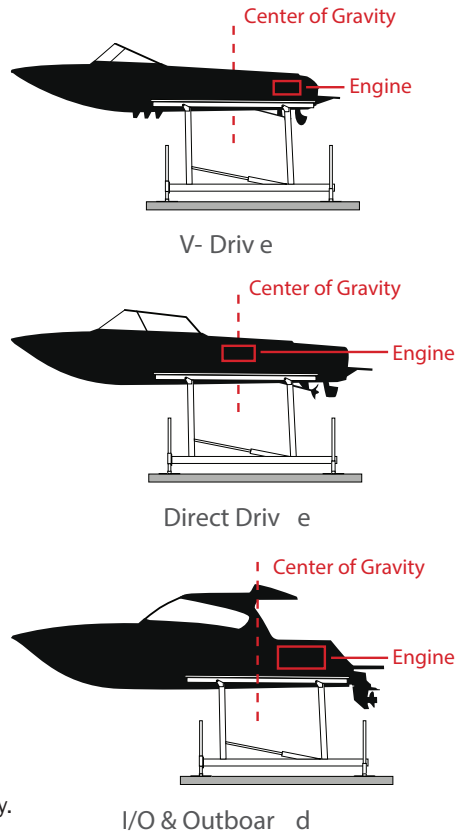

Shown: examples of fore and aft placement of the boat on the boat lift, which varies based on engine location.

IMPORTANT:

- If you purchase a new vessel, make sure does not exceed the weight capacity limits of the lift.
Maximum weight capacity can be found on the cover of this manual and on the H frame of the lift.
- Always turn power unit OFF when not in use.
- Keep inside of power unit box dry.
- To prevent unauthorized use lock box using padlock through the latch hasp.
- Securing your mooring line to the dock may provide additional security should the lift be lowered inadvertently.
- Leaving your bilge pump on the automatic setting may prevent the accumulation of rainwater in your vessel and overloading of the lift.
- Service your lift according to recommended Maintenance (page 19).
- Only use Basta Boatlifts approved fluid in lift. Contact Basta Boatlifts or authorized dealer for approved biodegradable hydraulic fluid.
- When not in use, store the lift in the upright position to prevent it from being an unknown hazard underwater.
- Store with the power off.

Step 1: Power on. Using the manual switch on the control panel, switch the On/Off switch to the “On” position.

Step 2: Lower the Lift. Using the Key Fob, unlock the Fob by pressing and releasing the lock button. Next, press the down button to lower the lift.

Step 3: Carefully guide the watercraft off the lift. Repeat in reverse order upon return.

For more questions or troubleshooting, consult your Authorized Dealer, the FAQs page on Bastaboatlifts.com or give us a call at 425-641-8911.

REMOTE CONTROL FOB INFORMATION



FOB POWER-UP

After turning on the ON/OFF switch in the dock box, the fob receiver requires a 5 second delay before the fob is enabled.

FOB OPERATION

Depress the unlock button (lower right), this will allow normal operation of the fob. The lockout is re-enabled after 60 seconds without a button press. Lift operation using the fob is limited to 120 seconds of continuous operation. If a longer cycle is needed it is necessary to release button and then re-depress.

FOB PROGRAMMING

1. Turn off the ON/OFF switch.
2. Wait 20 seconds.
3. Turn power back on, and within 5 seconds of power on, press both the UP and DOWN buttons on the fob simultaneously for 1 second then release.
4. Repeat steps 1-3 for additional Fobs. Up to four fobs may be enrolled. If a fifth fob is enrolled, the first enrolled fob will fall off the list.

BATTERY REPLACEMENT

Fob uses CR2032, 3 volt battery, commonly found online or at drug / hardware stores. Part numbers vary by manufacturer.

LOW BATTERY LOCKOUT

The remote control contains a low voltage lockout which is intended to protect the lift's battery from over-discharge.

When the battery drops below the low battery threshold during operation, further use of the fob is not allowed. The manual UP/DOWN switches will allow the lift to operate when sufficient battery power is present. The lift should be checked and charged prior to further operation.

TROUBLESHOOTING

If fob worked previously, but does not currently, replace fob battery or verify fob battery has greater than 3v. If fob does not work after replacement of fob battery, load test lift battery ensuring voltage does not drop below 11v while in use. If you have questions, contact your local dealer or Basta Boatlifts.



UNDERWATER LIGHTS

The underwater lights are activated whenever the lift is operated. The lights stay on for 2 minutes after the lift is operated. The lights may be manually turned on or off by depressing the lower left button on the remote fob. When manually enabled the lights will automatically turn off after 4 minutes. This prevents accidental battery discharge.

For more answers to frequently asked questions, visit:
bastaboatlifts.com/support/frequently-asked-questions/

Q: THE BATTERY WILL NOT HOLD A CHARGE

A: Verify that the loaded watercraft is not exceeding the weight capacity of the lift. If the battery is a flooded-cell type, check the electrolyte level.

A: Ensure the solar panel is properly connected.

A: Re-align the solar panel for proper exposure to the sun.

A: Recharge the battery with a 10 amp charger and check the charge again.

A: Have the battery tested. It may be old and require replacement.

A: If the lift is being used frequently during the day, it may be necessary to use a 110-volt maintainer/charger.

Q: THE REMOTE CONTROL IS NOT FUNCTIONING

A: The battery in the key fob transmitter may be low. Replace it with a new lithium CR2032. These are widely available at variety, hardware and even grocery stores. Polarity is marked on the battery holder.

A: Verify that the power unit battery is charged and connections are tight.

A: Reprogram the remote key fobs.

Q: THE PUMP DOESN'T RUN

A: Check the battery charge and recharge if necessary.

A: Check the battery connections, clean and re-secure if necessary.

Q: THE PUMP RUNS, BUT THE LIFT DOESN'T MOVE

A: Check the 'Quick Couplers' in the Power Unit. If they are not screwed together tight enough, built-in check valves will not allow fluid to flow. See Page 12.

A: Check the fluid level. See Page 19.

Q: DOES THE LIFT HAVE TO GO ALL THE WAY UP?

A: YES - in order for your lift to function as intended the lift must ALWAYS be stored in the full upright position when the watercraft is unattended.

Q: IS MY VESSEL SECURE?

A: Yes, once you verify that the lift is Over-Center™, switch off the power and lock the power unit box, there is less chance of theft.

Q: DO I NEED A MOORING LINE?

A: Under most circumstances one mooring line is sufficient to prevent the watercraft from drifting away if the lift is inadvertently lowered or the water level rises.

Q: HOW MUCH SUN DOES THE SOLAR PANEL NEED?

A: The panel should receive constant sun for at least 8 hours a day.

Q: HOW DO I CHANGE THE HYDRAULIC FLUID?

A: Our fluid should not require replacement for a considerable amount of time. If yours has been contaminated or the hydraulic power unit has been replaced, visit our web site at www.gobasta.com for detailed instructions.

Q: HOW DO I KNOW WHEN IT IS TIME TO CHANGE THE FLUID?

A: Basta Boatlifts' hydraulic fluid lasts between 3-6 years depending on usage. If you begin to hear an increased pitch in the sound of your pump motor, it is likely time to flush your hydraulic fluid. You can also tell by the clarity of the fluid. Fluid that is ready to be changed will be dark in color or cloudy. New fluid is clear.

Q: WHAT IF I GET A NEW VESSEL?

A: Re-leveling the lift may be necessary. A new lift will be required if the watercraft exceeds the weight capacity of your current lift.

FOR ASSISTANCE OR SERVICE:
Contact your local dealer or call
1-866-Go-Basta
or email: service@gobasta.com

BATTERY

Always use AGM batteries and follow battery manufacturer's warnings and instructions. Improper use, or use of other batteries, have the potential to produce flammable hydrogen gas which can result in serious injury or death. If you have limited solar exposure when the lift is not in use (typically winter), consider moving battery to a temperate environment (garage) and leave on battery maintainer.

SOLAR PANEL

Every Month (more as needed)
Wipe the solar panel with a clean, damp cloth to maintain its charging performance

IMPORTANT
ONLY ADD FLUID WITH LIFT IN
DOWN POSITION

Hydraulic fluid shown with lift
in the DOWN position

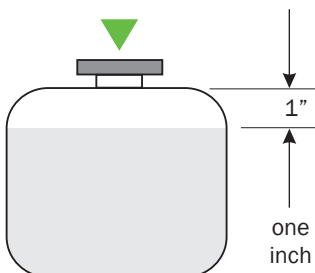

EVERY 6 MONTHS, WE RECOMMEND:

- Inspect hoses, cylinders and fittings for leaks and wear
- Check wire terminals for snugness and corrosion
- Check hydraulic fluid level and clarity. The hydraulic fluid level should be about one inch below the top of the reservoir with the lift completely down. DO NOT add fluid with the lift in the raised position! Use only Basta Boatlifts approved fluid. The lift power system does not consume fluid, so if fluid is low, look for leaks

EVERY 3-5 YEARS, DEPENDING ON US-AGE:

Flush hydraulic fluid. Visit the Basta Boatlifts service page for detailed instructions on how to perform a fluid flush. <https://bastaboatlifts.com/support/>.

Annual factory approved service is available. Contact your local dealer or Basta Boatlifts for additional information.

BASTA BOATLIFTS LIMITED WARRANTY



Thank you for investing in one of the finest PWC lifts in the world. We pride ourselves in knowing our product will safely and reliably be the conduit to your fun on the water. Welcome to the Basta Boatlifts family and Boat Happy!

Basta Inc. dba Basta Boatlifts (“Company”) warrants its Products (purchased after November 1, 2021) for non-commercial use for a period of,

- 16 years against manufacturing defects in steel and aluminum lift frame welds.
- 3 years against defects in materials and workmanship including hydraulic components, charging system, remote controls, dock box, bunks, canopies, and accessories.
- 1 year battery warranty when maintained in accordance with battery manufacturer’s guidance for batteries supplied by the Company,

to the original Purchaser (“Purchaser”), beginning from date of purchase of the Product from Company. If the Product is purchased from an authorized Company Reseller, the warranty term begins upon the date the new Product is sold to the end Purchaser (“Warranty Start Date”).

Annual inspection of the Product bolts, pins, hydraulics, pump, electronics, and welds, by a Company employee or Company authorized agent, shall be conducted. Failure to undertake such maintenance shall constitute “abuse” under Exclusions below.

Company has the right to modify Products at any time without incurring any obligation to make the same or similar modifications on Products previously manufactured or purchased.

Terms And Conditions:

Purchaser must register Product for a valid Warranty. Warranty registration may be found and submitted at:
<https://bastaboatlifts.com/support>.

Notice requirements and remedies:

If the Purchaser discovers a defect, the purchaser shall immediately notify the Company in writing by submission of a Warranty Request form. Warranty Request forms may be found and submitted at <https://bastaboatlifts.com/support>. Upon receipt of a complete Warranty Request form and after confirmation by Company that the Product is defective, the Company, or its authorized Company dealer or agent, will, at the Company’s sole discretion:

- 1- repair the Product or,
- 2-replace the defective part with a new or reconditioned part, or
- 3-refund the purchase price of the Product.

Confirmation of the defect shall require that reasonable proof of the defect be provided by Purchaser to Company or Company authorized agent, and may include that the Product or part be Returned to Company for inspection at the Purchaser’s initial expense. If the Purchaser chooses

to order a replacement part prior to the final determination of the warranty claim, Purchaser will be responsible for the cost of the replacement part and its shipping. If the part is determined to be a valid warranty claim, the customer will be credited the amount of the replacement part and its shipping. Replacement parts for Products outside the United States will be shipped in the next authorized Dealer shipment unless Purchaser agrees to pay for door to door freight of warranted Product. Warranty replacement shall not extend the original warranty of the defective Products.

Labor for warranty work to be provided by the Company’s Authorized dealer for a period of 3 years from Warranty Start Date, provided there is an active Authorized Dealer within 50 miles of the location of the Product. Labor will not be provided for direct purchases from Company or when an active Authorized Dealer is not located within 50 miles of the location of the Product.

Warranty requests received after expiration of warranty term will not be covered under this warranty regardless of when the defect occurred or was discovered.

Exclusions:

Product changes caused by age or environment (such as marine growth, heat, corrosion or electrolysis) shall not constitute a defect. In addition, this warranty does not cover or apply to the following: damages caused by or due to without limitation: accidents, collision, fire, flood, wind, ice, or any other natural disaster or acts of God, abuse, misuse, overloading, improper watercraft loading, use when out of level, faulty assembly or installation. Lift components’ fluid levels and condition, including battery electrolyte (water and acid), hydraulic fluid and strainer cleaning are maintenance items and are not covered by this warranty. Sacrificial anodes (zincs), cosmetic concerns and custom coatings are not covered by this warranty.

Warranty is void if the Product has been modified in any way or if any Company serial number has been removed or defaced. Product purchased from Company, but used on non-Company Products are excluded from this warranty.

Limitations:

To the maximum extent permitted by law except as expressly stated herein, there are no warranties, expressed or implied, by operation of law or otherwise, of the Product furnished under this Agreement. Seller disclaims any implied warranty of merchantability or fitness for a particular purpose. The sole remedy for liability of any kind shall be limited to the remedies provided in this warranty and shall in no event include any incidental, indirect, special or consequential damages or loss of use, revenue or profit. Should the company nevertheless be found liable for any damages, the total liability of the company shall be limited to the purchase price of the Product.